

VIRTUS AST

Advanced Spreading Technology

VIRTUS AST

Advanced Spreading Technology

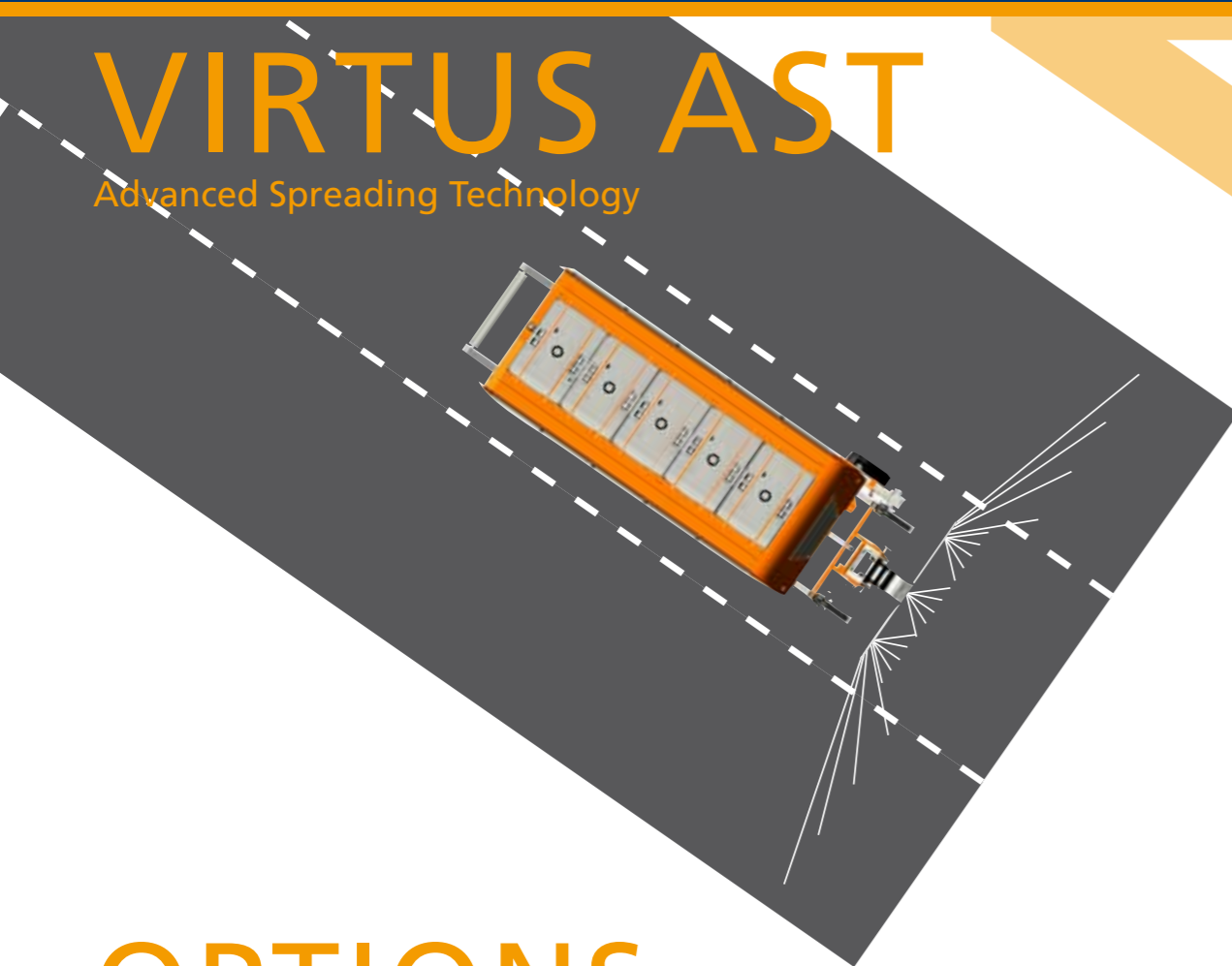

OPTIONS



EpoSat®
GPS-controlled spreading

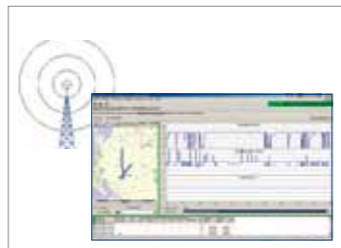

Data collection - GSM & GPRS

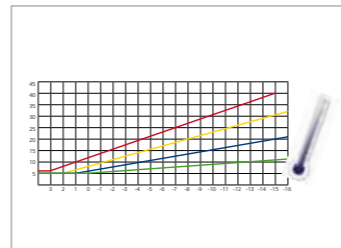

EpoTherm

VIRTUS AST

- Reduced environmental damage
- Reduced material consumption
- Revolutionary design
- High-speed spreading
- Dosing accuracy
- Improved spreading pattern settings
- Service-friendly



Epoke® A/S
 Vejenvvej 50, Askov
 DK-6600 Vejen
 Tel. +45 76 96 22 00
 Fax +45 75 36 38 67
 epoke@epoke.dk
 www.epoke.dk



In order to maintain the high and uniform product standard Epoke® A/S has been certified by Lloyd's register to ISO 9001:2008.

TLG B-3 approval
 GS approval
 E1 approval
 RoHS directive
 WEEE directive



080210 - pla



- de-icing of roads!

Liquid spreading

Liquid spreading enables a significant reduction of spreading material, thus making it possible to spread as little as possible, but as much as necessary. A lower material consumption contributes to overall cost reductions.

Experience shows that the salt amount by liquid spreading is reduced significantly, resulting in reduced environmental impact. Many years of testing have demonstrated that liquid is effective immediately after delivery on the road surface.

Therefore, liquid spreading is extremely suitable for preventive slippery roads control.

The development work of Epoke A/S within liquid spreading technology has resulted in a new spreader model. The new liquid spreader features epoch-making design, operation and robustness.

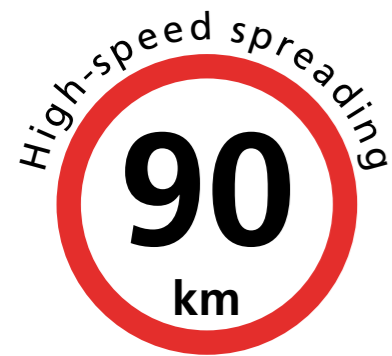

High-speed spreading

The VIRTUS AST is a fully automatic, road-speed dependent liquid spreader, and the spreading material dispensed as well as the spreading width are corrected in accordance with current driving speed.

VIRTUS AST is available in 3 variants of 7500 l, 10000 l and 12500 l, respectively.



The modular-built liquid tanks ensure a stable distribution of the liquid contents in the tanks. The durable liquid tanks are made of thermoplastic material resistant to extreme climatic conditions.

A service-friendly machine house holding central components in a well-arranged and easily accessible manner contributes to optimizing the working conditions for the drivers as well as the service/maintenance staff.

A combination of fan nozzles and jet nozzles permits a working width range of 3-11 meters. The width may be increased in 1-meter steps, which allows corrections due to side wind and spreading in bus bays and turn lanes.

The special Spratronic-nozzles make liquid spraying at speeds up to 90 km/h possible. The increased speed results in a faster passage of the route. Furthermore, the spreader is capable of following the flow and thus does not impede traffic.

Drive systems

-  **Hydraulic system**
SH – vehicle hydraulic system.
-  **Diesel engine**
SE – separate air-cooled diesel engine.
-  **Road wheel**
SW – the "5th wheel"

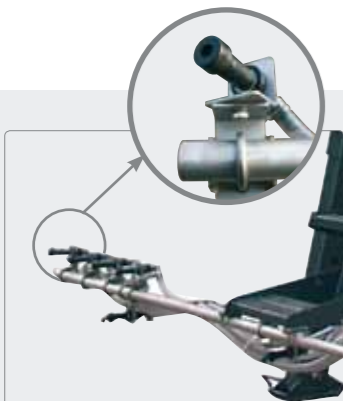

High-speed spreading by Spratronic-nozzles. Spreading at all speeds up to 90 km/h.



Modular liquid tank construction.



Service-friendly machine house permitting quick access to computer unit, valves and liquid pumps.



Logically built liquid system featuring diaphragm pump.



Various off-loading systems optionally available.



Wireless EpoMaster® IV remote control ensures quick material shift and control of spreading pattern, spreading quantity and symmetry adjustments.